

trometer,<sup>7</sup> and the proton spectra at 270 MHz were obtained on a Bruker HX270.<sup>8</sup> The <sup>13</sup>C spectra were recorded on a Varian CFT20 spectrometer. For the <sup>1</sup>H spectra, 50 mg of 1,3-dithiane (Willow Brook) was placed in a 5-mm NMR tube, and 0.3 mL of FSO<sub>3</sub>H (Aldrich) was added in a dropwise fashion. The tube was shaken and the spectrum recorded. For the <sup>13</sup>C spectra, 300 mg of 1,3-dithiane and 1.2 mL of FSO<sub>3</sub>H were used. After about 12 h at room temperature or 1 h at 70 °C, a precipitate formed and new peaks appeared irreversibly in the <sup>1</sup>H spectrum. Spectra were always recorded before this process had progressed to any significant extent. A sample prepared for the <sup>13</sup>C spectrum was quenched by addition to 10 mL of H<sub>2</sub>O. The solution was extracted three times with ether. A small precipitate developed on the first extraction, but it could not be identified because of its low solubility. The organics were dried, and the solvent was evaporated. The <sup>1</sup>H spectrum of the residue showed it to be uncontaminated 1,3-dithiane, which could be isolated in 35–50% yield.

**1-Methyl-1,3-dithianium Iodide.** To 6 g (0.05 mol) of 1,3-dithiane in 50 mL of acetone was added 21.3 g of CH<sub>3</sub>I. The flask was stoppered and stored at room temperature for 48 h in the dark. White crystals of the product were isolated and recrystallized from CH<sub>3</sub>OH (4 g, 0.015 mol, 30.5%); mp 126–128 °C; NMR (D<sub>2</sub>O vs. external Me<sub>4</sub>Si in CCl<sub>4</sub>) δ 2.92 (m, H-5, 2 H), 3.51 (t, H-4, 2 H), 3.58 (s, CH<sub>3</sub>, 3 H), 3.99 (m, H-6, 2 H), 5.21 (AB q, Δν = 0.35 ppm, J = 13.8 Hz,

H-2, 2 H). Anal. Calcd for C<sub>5</sub>H<sub>11</sub>S<sub>2</sub>I: C, 22.91; H, 4.23. Found: C, 22.82; H, 3.89.

## References and Notes

- (1) (a) This work was supported by the National Science Foundation, Grants CHE-75-05006 and CHE-77-08384, and by the donors of the Petroleum Research Fund, administered by the American Chemical Society; (b) Petroleum Research Fund Postdoctoral Fellow; (c) On leave from the Institute of Drug Research, Pharmaceutical Faculty of the Medical Academy, Łódź, Poland.
- (2) J. B. Lambert and R. G. Keske, *J. Org. Chem.*, **31**, 3429 (1966).
- (3) (a) S. A. Khan, J. B. Lambert, O. Hernandez, and F. A. Carey, *J. Am. Chem. Soc.*, **97**, 1468 (1975); (b) M. J. Cook and A. P. Tonge, *Tetrahedron Lett.*, 849 (1973); *J. Chem. Soc., Perkin Trans. 2*, 767 (1974).
- (4) F. A. Carey, P. M. Smith, R. J. Maher, and R. F. Bryan, *J. Org. Chem.*, **42**, 961 (1977); N. L. Allinger and J. Kao, *Tetrahedron*, **23**, 529 (1976).
- (5) J. B. Lambert, R. G. Keske, and D. K. Weary, *J. Am. Chem. Soc.*, **89**, 5921 (1967); spectra of alkyl-substituted protonated thianes have been reported recently by R. L. Willer and E. L. Eliel, *Org. Magn. Reson.*, **9**, 285 (1977).
- (6) J. B. Lambert, D. S. Bailey, and C. E. Mixan, *J. Org. Chem.*, **37**, 377 (1972).
- (7) We are very grateful to Dr. Richard Egan and Mr. Momir Cirovic of Abbott Laboratories, North Chicago, Ill., who carried out these experiments for us on a Varian HA100.
- (8) We thank Mr. Robert Dykstra for recording these spectra on the Bruker 270-MHz superconducting instrument at the Department of Chemistry, the University of Chicago.
- (9) J. B. Lambert, *Top. Stereochem.*, **6**, 19 (1971).
- (10) J. B. Lambert and J. E. Goldstein, *J. Am. Chem. Soc.*, **99**, 5689 (1977).

## Molecular-Beam Study of the Activation Energy Requirements for the Dioxetane Reaction

K. T. Alben, A. Auerbach, W. M. Ollison, J. Weiner, and R. J. Cross, Jr.\*

Contribution from the Department of Chemistry, Yale University, New Haven, Connecticut 06520. Received July 22, 1977

**Abstract:** Using crossed, seeded nozzle beams we determined the amount and kind of activation energy required for the chemiluminescent dioxetane reaction, O<sub>2</sub>\*(<sup>1</sup>Δ<sub>g</sub>) + R<sub>1</sub>R<sub>2</sub>C=CR<sub>3</sub>R<sub>4</sub> → R<sub>1</sub>R<sub>2</sub>C=O\* + R<sub>3</sub>R<sub>4</sub>C=O. By varying the composition and temperature of the stagnant gas behind the nozzle we were able to study the reactive cross section as a function separately of translational energy and vibrational temperature. Three olefins were studied in detail: *N,N*-dimethylisobutenylamine, which gave no change in cross section with either variable; and methyl vinyl ether and 1,1-diethoxyethylene, whose cross sections were independent of vibrational temperature but showed a sharp rise with increasing translational energy.

### Introduction

Most chemical reactions have an activation energy, which means that energy must be supplied to the reactants to make them go. Yet there is very little information on what form of energy (translation, rotation, or vibration) is needed. Brooks et al.<sup>1</sup> demonstrated that the slightly endoergic reaction K + HCl → KCl + H was considerably enhanced by vibrational excitation in HCl but almost unaffected by increase in translational energy. Jaffe and Anderson<sup>2</sup> found that the reaction HI + DI → HD + 2I would not proceed even if translational energy was supplied far in excess of the known activation energy. Polanyi<sup>3</sup> has done Monte Carlo calculations for three-atom system which show that, if the crest of the barrier (transition state) is located in the entrance valley, the reaction is promoted by translational energy while vibrational energy is ineffective. Translational energy gives the reactants a velocity aimed toward the barrier while vibrational energy does not. Conversely, if the barrier is in the exit valley, the reaction is promoted by vibrational energy but not translational energy.

The reaction chosen for this study, the dioxetane reaction, is itself an intriguing reaction which has long interested organic chemists.<sup>4</sup> It is chemiluminescent which vastly enhances its

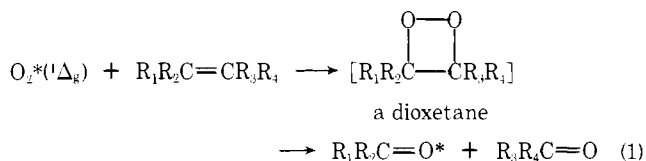

detectability. The formation of the dioxetane intermediate in its ground state is symmetry forbidden as a concerted process.<sup>4b,5</sup> The kinetics have been extensively studied in the gas<sup>6–8</sup> and liquid phases.<sup>4</sup>

The experimental technique used here involves supersonic nozzle beams.<sup>9</sup> When a gas is expanded through a small hole into a vacuum, it undergoes an adiabatic cooling, converting the enthalpy due to translation and rotation in the stagnant gas behind the nozzle into translational energy in the beam, while the translational and rotational temperatures in the beam drop to a few degrees Kelvin. The result is a nearly monoenergetic molecular beam with a velocity determined by the initial temperature and by the average molecular weight of the initial, stagnant gas. By using different mixtures of a heavy reactant and a light carrier gas one can both accelerate the reactant and vary its velocity. During the expansion the molecules undergo only a few dozen collisions before entering a nearly collision-

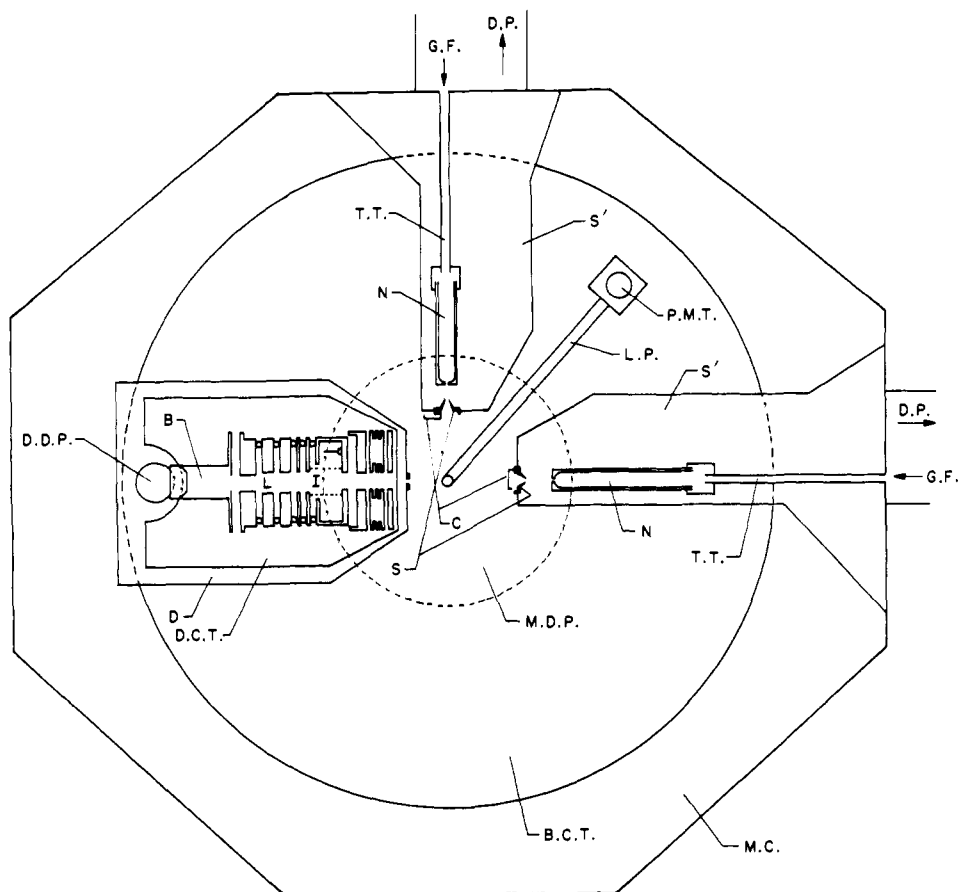

**Figure 1.** Schematic of the apparatus: D.D.P., detector diffusion pump; B, 90° bend; D, detector; D.C.T., detector cold trap; L, lens; I, ionizer; B.C.T., bottom cold trap; M.D.P., main chamber diffusion pump; M.C., main chamber; C, chopper; S, skimmer; N, nozzle; S', shroud; T.T., Teflon tubing; G.F., gas flow; D.P., 6-in. diffusion pump; L.P., light pipe; P.M.T., photomultiplier tube.

free state in the beam. Since vibrational relaxation is very inefficient, the distribution of vibrational states is only slightly affected and may be closely approximated by a Boltzmann distribution at the source temperature. By varying the temperature and composition of the stagnant gas before expansion one can separately vary the translational energy and the vibrational temperature of the beam and thereby determine the type of energy needed for the activation of a chemical reaction.

### Apparatus Description

The apparatus consists of two nozzles, each mounted in a differentially pumped region such that the beams interact at 90°. Two detectors are provided: a mass spectrometer mounted on the rotatable lid of the main vacuum chamber, and a photomultiplier to detect the chemiluminescence. A detailed description of the components follows. Figure 1 shows a schematic diagram of the apparatus.

**Main Vacuum Chamber.** The main vacuum chamber is an octagonal "birdcage" made of welded aluminum, 30 in. high and 36 in. in diameter. The eight sides are removable flanges. It is pumped by a 10-in. oil diffusion pump mounted on the base. On the floor of the chamber, directly over the diffusion pump, is a large liquid nitrogen cooled cold trap, with a set of copper plates extending up several of the walls of the apparatus to provide additional cryogenic pumping. On the top of the chamber is a rotatable lid, 36 in. o.d., which supports the mass filter and detector. The lid is sealed by a single o-ring. Two Teflon rings form a bearing for the vertical force and four pairs of needle bearings take the sideways force during rotation. The lid is rotated by a motor-gear assembly.

**Beam Sources.** The two sources are mounted at 90° off two of the side flanges. Stainless steel "shrouds" inside the main chamber completely enclose the sources except for the beam exits. Each source is pumped by a 6-in. oil diffusion pump attached to the chamber wall. The nozzle and skimmer are mounted on a support bracket which allows the nozzle-skimmer distance to be adjusted from outside the

vacuum. The nozzle is a quartz tube which was melted closed and then ground back to obtain the desired orifice. The skimmers are made of stainless steel, lapped to provide a sharp edge. They have an inside angle of 50° and an outside angle of 70°. Each beam may be blocked by a flag mounted off a stepping motor mounted inside the main chamber.

The metastable oxygen ( $^1\Delta_g$ ) beam is prepared by passing a mixture of 5 Torr  $O_2$  and 10 Torr He through an electrodeless microwave discharge operated at 70 W. A small droplet of mercury provides a film of HgO which catalyzes<sup>10</sup> the recombination of oxygen atoms. A small quantity of  $NO_2$  is also added after the discharge to remove the last trace of oxygen atoms,<sup>10</sup> since these react with residual NO produced in the discharge to give a chemiluminescent background:

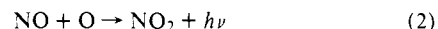

As a result of these measures, and a careful control of other light leaks, our photon background is reduced to ~5 counts/s. By adding 2,5-dimethylfuran to the gas just upstream from the nozzle we are able to titrate to  $O_2^*(^1\Delta_g)$  using the mass spectrometer detector to measure the end point.<sup>10</sup> The  $O_2^*$  adds across the two double bonds in furan to form a bicyclic endoperoxide. The conversion of  $O_2$  to  $O_2^*$  is 5–10% depending on the tuning of the discharge. All chemiluminescence is stopped by turning off the discharge or by adding dimethylfuran to the gas following the discharge, thus establishing  $O_2(^1\Delta_g)$  as the reacting species. The nozzle for this beam is 0.64 mm i.d. and the skimmer 0.81 mm i.d. The resulting beam has a spread of 30° fwhm at the detector.

The olefin beam is prepared by mixing 4–10 Torr of the olefin with 100–170 Torr of the carrier gas ( $H_2$ , He, Ne, or Ar) in a vacuum line. For liquid olefins this is done using a bubbler; for gaseous olefins a pair of leak valves is used. The total pressure is measured with a mercury manometer, and the gas composition is determined by bleeding the mixture through a leak valve into an evacuated container. After filling, the olefin is frozen out with liquid nitrogen, the carrier pumped off, and the olefin allowed to vaporize. The partial pressure of the olefin is then measured by a small mercury manometer built onto the sam-

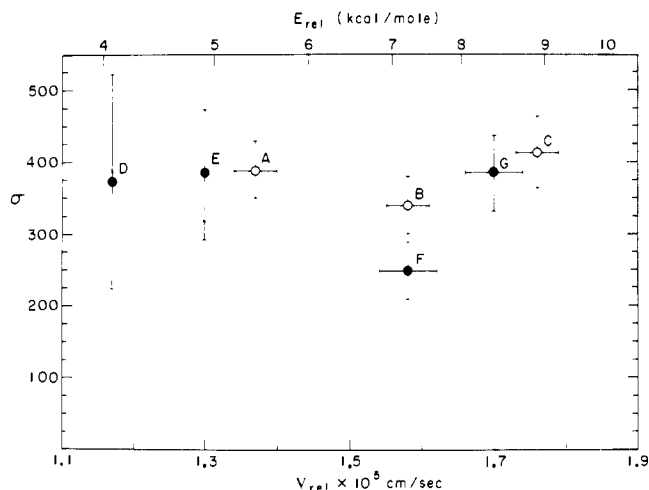

**Figure 2.** Relative cross section (in arbitrary units) vs. relative velocity for *N,N*-dimethylisobutenylamine. O, He driver gas at a constant amine pressure ( $11 \pm 1$  Torr). The stagnant temperature and pressure ( $T_0$ ,  $P_{\text{total}}$ ) are varied. A, B, C taken respectively at (298 K, 128 Torr), (415 K, 155 Torr), and (558 K, 175 Torr). ●, constant amine pressure ( $11 \pm 1$  Torr) and constant nozzle temperature 420 K while carrier gases are varied. D, E, F, G taken respectively at (Ar carrier, 199 Torr), (Ne, 202 Torr), (He, 158 Torr), and ( $\text{H}_2$ , 168 Torr).

pling vessel. For this beam the nozzle is wrapped with nichrome wire and a thermocouple attached to the middle. The nozzle tube was packed with glass chips to facilitate thermal equilibration. The nozzle is 0.13 mm i.d. and the skimmer 0.38 mm i.d. The beam is roughly  $4^\circ$  fwhm wide at the detector.

Since the machine does not have a velocity analyzer, we were forced to calculate all the beam velocities using known formulas for nozzle beams.<sup>11</sup> Let  $\gamma_a$  and  $m_a$  be the pressure-weighted averages of  $\gamma = c_p/c_v$  and mass,  $x$  be the nozzle-skimmer distance,  $D$  be the nozzle diameter, and  $T_0$  the source temperature. The stagnation sonic velocity is<sup>11</sup>

$$a_0 = (\gamma_a RT_0 / m_a)^{1/2} \quad (3)$$

and the Mach number is

$$M = A \left( \frac{x - x_0}{D} \right)^{\gamma_a - 1} - \frac{\gamma_a + 1}{2(\gamma_a - 1)A} \left( \frac{x - x_0}{D} \right)^{1 - \gamma_a} \quad (4)$$

where  $A$  is a slowly varying function of  $\gamma_a$  and  $x_0$  a small correction to  $x$ .<sup>11</sup> The beam velocity is

$$v = Ma_0 \left[ \frac{\gamma_a - 1}{2} M^2 + 1 \right]^{-1/2} \approx \left[ \frac{2\gamma_a RT_0}{m_a(\gamma_a - 1)} \right]^{1/2} \quad (5)$$

In our case  $M > 9$ . In the case of light carrier gases ( $\text{H}_2$ , He) a correction for nozzle slip was made.<sup>11b,c</sup> This results in a slightly lower velocity than that given by eq 5. For  $\text{H}_2$  an extra correction was made for the incomplete relaxation of the rotational degrees of freedom in  $\text{H}_2$ .<sup>12a</sup> The velocity is<sup>12b</sup>

$$v = [v'^2 - 2RT_1/Ma]^{1/2} \quad (6)$$

where  $T_1 = 2T_0/(\gamma_a + 1)$ , and  $v'$  is the velocity given by eq 5. This correction includes rotational relaxation from the stagnant gas to the throat of the nozzle ( $M = 1$ ), but assumes that the rotational temperature is frozen at this point. This approximation agrees within a few percent with the velocities measured by Gallagher<sup>12c</sup> using beams of  $\text{H}_2$ . The accuracy of our calculated velocities is tested by the agreement between cross sections taken under different beam conditions and by the agreement between our data and thermal kinetic data taken in flow experiments (see below).

**Photomultiplier Detector.** A glass-fiber light pipe is positioned directly below the beam scattering center and connected to a photomultiplier (RCA 1P28), mounted on the liquid nitrogen cooled cold trap. Cooling the multiplier reduces the dark current to 5 counts/s. The light pipe views a large solid angle without interfering with the sources. The phototube output is amplified by a pulse amplifier/discriminator and counted.

**Mass-Spectrometer Detector.** The second detector is mounted in a separately pumped chamber attached to the rotatable lid. Pumping

is accomplished by a 2-in. oil diffusion pump, backed by the main vacuum chamber, and by extensive cryogenic pumping. The ionizer is of the Brink design,<sup>13</sup> and is surrounded by two cylindrical, liquid nitrogen cooled baffles. In front of and behind the ionizer are two systems of linear baffles that have the effect, for condensables, of many nested chambers. Thus molecules not traveling along the beam path must make many collisions with liquid nitrogen cooled surfaces before entering the ionizer. Those that do are quickly removed. Ions are extracted by a three-element lens, bent by  $90^\circ$  and mass analyzed by a quadrupole mass filter (Extranuclear Corp. with a D-2 head). The ions are detected by a Daly detector<sup>14</sup>—they strike an aluminum surface at  $-21$  kV thereby ejecting electrons which enter a scintillator which then emits light which, in turn, is detected by a photomultiplier (RCA 8575). The multiplier output is measured either by an electrometer for high levels or a pulse counting system for low levels.

**Experimental Procedure.** After stabilizing both beams, the intensity of the olefin beam is periodically measured by the mass spectrometer. All measured cross sections are normalized by dividing by this intensity, since it changes as the beam conditions are altered during a series of runs. The operating conditions of the  $\text{O}_2$  beam are left unchanged and are reproducible from day to day. During a run the beam choppers are run at 5 Hz,  $90^\circ$  out of phase from each other. The output pulses from the photomultiplier detector are gated into one of two counters. The gate is turned on after the chopper is closed. One counter sums the on-on and off-off cycles; the other sums the on-off and off-on cycles. The difference is the signal produced by the beam-beam reaction. Contributions caused by reactions involving the background gas are canceled out. The relative cross section is then computed by dividing this difference by the intensity of the olefin beam. Measurements taken on different days are normalized to some standard condition such as a particular gas composition and nozzle temperature.

Despite several attempts we have been unable to see the products of the reaction with the mass spectrometer. We are thus unable to measure the angular or energy distributions of the products.

## Results

Three systems were examined in detail: *N,N*-dimethylisobutenylamine; methyl vinyl ether; and 1,1-diehoxyethylene (ketene diethyl acetal). Several other systems were studied with less detail. *N,N*-Dimethylisobutenylamine,  $(\text{CH}_3)_2\text{C}=\text{CHN}(\text{CH}_3)_2$ , was obtained from Pfaltz and Bauer Chemical Co. and purified by distillation under vacuum and then  $\text{N}_2$ . Figure 2 shows the relative cross section  $\sigma$  vs. relative velocity for the carrier gases  $\text{H}_2$ , He, Ne, and Ar. As is readily apparent, there is little change in the reactive cross section over the whole region. The experiment covers the range  $300 \text{ K} \leq T_{\text{vib}} \leq 600 \text{ K}$  and  $4 \leq E_{\text{rel}} \leq 9 \text{ kcal/mol}$  (0.17–0.4 eV). Subsequent to our measurements Dr. Denis J. Bogan<sup>15</sup> of the Naval Research Laboratory measured the Arrhenius parameters for this reaction using a discharge-flow system and reported an activation energy of  $2.56 \pm 0.25 \text{ kcal/mol}$  over the temperature range of 298–730 K. He determined further that the reaction was first order in each component, in agreement with our results, and that the light was emitted by the acetone product. Since all our measurements were taken at relative energies well above the activation energy, one would expect only a small variation of cross section with either  $T_{\text{vib}}$  or  $E_{\text{rel}}$ . One result, common to all systems studied here, is that the reaction 1 must occur in a single bimolecular collision. At the low pressures in our system there is little chance for multicolision events. This is in agreement with Bogan's results.<sup>7,8,15</sup>

Methyl vinyl ether was obtained from Matheson Gas Co. and used without further purification. The results are shown in Figure 3 as cross section vs. relative velocity. The relative velocity was varied in two ways, by changing the nozzle temperature and by changing the ratio of olefin to hydrogen in the gas mixture. The agreement of both sets of data shows that  $\sigma$  is independent of  $T_{\text{vib}}$  and depends only on translational energy. We cannot detect light using He as a carrier gas, even at 700 K. The dependence of  $\sigma$  on  $v_{\text{rel}}$  shows the expected steep rise above a threshold. The data may be fit fairly well by the classic

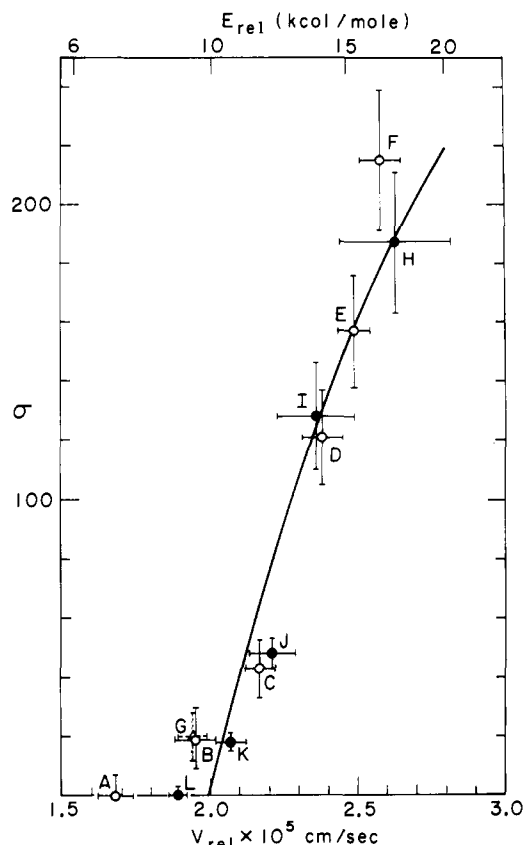
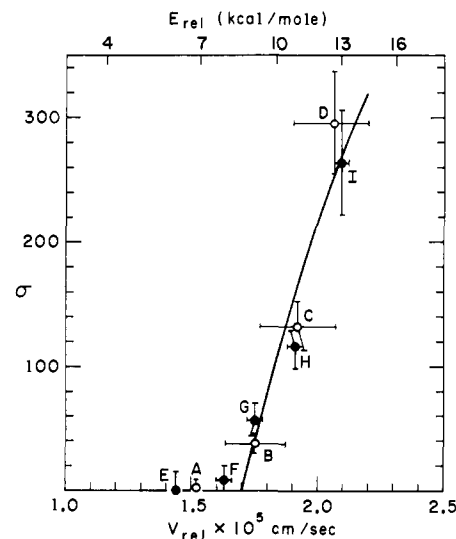

**Figure 3.** Relative cross section vs. relative velocity for methyl vinyl ether. O, H<sub>2</sub> carrier gas at a constant ether pressure (4.5 ± 0.5 Torr). The temperature of the nozzle is varied. A–F were taken with (T<sub>0</sub>, P<sub>total</sub>) at (298 K, 84 Torr), (393 K, 100 Torr), (483 K, 118 Torr), (573 K, 128 Torr), (623 K, 134 Torr), and (668 K, 138 Torr), respectively. Δ, H<sub>2</sub> carrier gas. The ether pressure was increased to 30 ± 2 Torr G (663 K, 259 Torr). ●, H<sub>2</sub> carrier gas varying the composition of methyl vinyl ether at a fixed nozzle temperature of 623 K. H–L taken respectively at (2.3%, 132 Torr), (4.3%, 141 Torr), (5.6% 161 Torr), (7%, 185 Torr), and (11.7%, 240 Torr).

line-of-centers model which assumes that the reaction will proceed if the component of energy along the line of centers is greater than the threshold energy. The curve in Figure 3 is the best fit to the line-of-centers model (a two-parameter fit). The threshold energy is 9.8 ± 1 kcal/mol. In the line-of-centers model the threshold energy is equal to the activation energy. Bogan<sup>8</sup> has measured the activation energy  $E_a$  for this reaction to be 10–12 kcal/mol, in good agreement with our value.

Diethoxyethylene (ketene diethyl acetal), CH<sub>2</sub>=C(OC<sub>2</sub>H<sub>5</sub>)<sub>2</sub>, was prepared by the procedure of McElvain and Kundiger.<sup>16</sup> NMR analysis showed a purity of ~95%. It was stable for months if kept in a container previously washed in alcoholic KOH. The results for this molecule are shown in Figure 4. Both helium and hydrogen can be used as carrier gases, and the results are superimposable even though the results for helium are obtained at much higher nozzle temperatures. Again, vibrational temperature has no effect on our results. As with methyl vinyl ether the results may be fit to the line-of-centers model with possible tailing at low energies. The threshold (activation) energy is 7–9 kcal/mol. There is no reported value of the activation energy for the gas-phase rate constant.

We examined several additional cases in less detail. Ethyl vinyl ether has about the same reactivity as methyl vinyl ether in agreement with Bogan's results.<sup>8</sup> Since the methyl compound is a gas and easier to handle, we did most of our work with that. Divinyl ether was synthesized by the procedure of Brandsma and Arens<sup>17</sup> in the hope that it would prove more reactive than the methyl or ethyl vinyl ethers. No reaction was



**Figure 4.** Relative cross section vs. relative velocity for 1,1 diethoxyethylene. O, H<sub>2</sub> carrier gas at constant ethylene pressure (4 ± 1 Torr). The temperature of the nozzle is varied. A–D taken respectively at (298 K, 106 Torr), (390 K, 127 Torr), (473 K, 140 Torr), and (570 K, 151 Torr). ●, He carrier gas at constant ethylene pressure (4.5 ± 0.5 Torr). The temperature of the nozzle is again varied. E–I taken respectively at (298 K, 125 Torr), (400 K, 152 Torr), (473 K, 166 Torr), (573 K, 178 Torr), and (673 K, 188 Torr).

seen under any condition. *N,N*-Diethylvinylamine [CH<sub>2</sub>=CHN(C<sub>2</sub>H<sub>5</sub>)<sub>2</sub>] was synthesized by the procedure of Laban and Mayer.<sup>18</sup> It seemed to be about as reactive as *N,N*-dimethylisobutenylamine, but polymerized so rapidly that we could not study it in detail. 2-Methoxypropene was synthesized by the procedure of Newman and Zwan.<sup>19</sup> We could detect chemiluminescence only at 673 K with H<sub>2</sub> as the carrier gas. The threshold was too high for a complete study. However, the fact that luminescence was seen at all is interesting since there is a competing reaction, the "ene" reaction<sup>4b,10,20</sup>. This

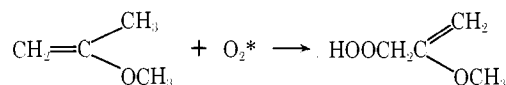

reaction typically has an activation energy of only a few kcal/mol,<sup>20</sup> much lower than our observed threshold for the dioxetane reaction in this case. The implication of this is that the two reactions proceed by quite different paths and do not involve a common dioxetane intermediate. No chemiluminescence was observed from acrylonitrile or from tetrakis(dimethylamino)ethylene. The latter case is interesting since the molecule undergoes a chemiluminescent reaction in solution with ground-state O<sub>2</sub>(<sup>3</sup>Σ<sub>g</sub>) in what is evidently a complicated mechanism.<sup>21</sup>

## Discussion

Our results clearly indicate that translational energy can serve as the activation energy for the dioxetane reaction (eq 1). Over the range of our experiments, a change of the vibrational temperature has no effect on the reaction. There are two extreme cases involving both translational energy and vibrational energy. A reaction may require a specific mixture of the two such that they are not interchangeable. In this case one would expect that the cross section  $\sigma(T_{\text{vib}})$  would approximate the Arrhenius equation with an activation energy equal to the vibrational threshold. We can put an upper limit of ~1.5 kcal/mol on this threshold. Since both beams are rotationally cooled, there can be no specific requirement for rotational energy. At the other extreme, one can have both translational and vibrational energy interchangeable. With the translational energy near or above the threshold the effect of vibrational

energy is equivalent to adding  $mkT$  to the translational energy, where  $m$  is the number of modes contributing. Our uncertainty is large enough so that we cannot see the effect of a single mode, but we would expect to see a measurable effect if more than four modes contributed. If both translational and vibrational energy were interchangeable, we would expect that the activation energy for a thermal study would be lower by  $mkT$  than the threshold energy obtained by translational energy alone. Our threshold energy for methyl vinyl ether is slightly lower than Bogan's activation energy.<sup>8</sup> Again we cannot resolve a single mode, but we can resolve more than four modes. If vibrational energy were favored over translational energy, the activation energy would be lower than the translational threshold, which is not the case.

A high specificity in activation energy for smaller systems has been seen in several theoretical studies<sup>3</sup> and in a few experimental cases.<sup>1,2</sup> By extension of Polanyi's model for three-body reactions, it can be inferred that the dioxetane reaction has its activation barrier in the entrance valley of the potential-energy surface. Translational energy aims the velocity toward the barrier thus promoting the reaction. Vibrational energy does not. The results also indicate that the activation process involves little or no change in bond lengths or angles, because, if this were the case, vibrational energy would be required for the reaction.

At this point we should review what is known about the potential energy surface for reaction 1. The data are most extensive for the parent reaction  $O_2^* + C_2H_4 \rightarrow 2CH_2O + h\nu$ . Bogan has measured an activation energy of 21 kcal/mol for the reaction.<sup>7</sup> Substituted dioxetanes can be synthesized and subsequently pyrolyzed to give the second half of reaction 1. Calculations<sup>22,23</sup> on the parent 1,2-dioxetane give the ground-state energy 36–37 kcal/mol below the reactants and 26–31 kcal/mol below  $CH_2O^* + CH_2O$ . Although we have no data on the angular distributions of the products, the reaction probably goes by way of a long-lived complex (vibrationally excited dioxetane), since this is usually what happens when a deep well exists in the surface. The nature of the activation barrier has been examined by several groups.<sup>5,22</sup> A correlation of molecular orbitals shows that the ground state of  $C_2H_4 + O_2(^1\Delta_g)$  correlates to an excited state of dioxetane and vice versa, a classic case of a reaction forbidden by the Woodward–Hoffmann rules. The barrier may be the avoided crossing of these two potential energy surfaces in which case the reaction may still be concerted. Dewar<sup>24</sup> has suggested that the lowest activation energy involves the end-on addition of  $O_2^*$  to the double bond to form a piroxirane (three-membered ring) which subsequently adds the remaining oxygen atom to form dioxetane. This is disputed by Harding and Goddard,<sup>23</sup> who favor the addition of  $O_2^*$  to one end of the  $C=C$  bond to form a CCOO biradical. In the  $C_{2v}$  symmetry group  $O_2^*(^1\Delta_g) + C_2H_4$  form two surfaces of  $A_1$  and  $B_2$  symmetry. The ground state of dioxetane has  $A_1$  symmetry. The products  $CH_2=O$  ( $X, ^1A_1$ ) and  $CH_2=O^*$  ( $A, ^1A_2$ ) fall on two surfaces of  $A_2$  and  $B_2$  symmetry. The breakup of the dioxetane then requires a surface crossing and a vibronic interaction. Since the dioxetane is formed with a large vibrational energy, there is no problem

with vibronic coupling. Since the lifetime of the dioxetane may be many vibrations, the coupling between the two surfaces need not be large. The above considerations apply to our cases only in a qualitative sense since the addition of substituent groups affects the various energies and breaks the symmetries of various parts of the reaction.

**Acknowledgments.** This work would not have been possible without the help of many people. We are indebted to Mr. A. Disco and M. S. Ladzinski for help in designing the apparatus. We had many long conversations with Professors J. B. Anderson and J. B. Fenn on the construction and applications of nozzle beams. We received invaluable help from Professor Y. T. Lee on the construction of the detector. Professor H. H. Wasserman and members of his group, particularly Mr. J. Ives and Mr. J. Wu, were very helpful in advising us on the organic chemistry of these systems. We had several long conversations with Dr. D. J. Bogan, who kindly measured the activation energy for  $N,N$ -dimethylisobutenylamine and allowed us to use his data prior to publication. We are grateful to Dr. C. A. Heller of the Naval Weapons Center, China Lake, Calif., for his gift of tetrakis(dimethylamino)ethylene. Finally, we are indebted to the National Science Foundation and the National Aeronautics and Space Administration for the financial support of this work.

## References and Notes

- (1) (a) T. J. Odiorne, J. V. V. Kasper, and P. R. Brooks, *J. Chem. Phys.*, **55**, 1980 (1971); (b) J. G. Pruett, F. R. Grabiner, and P. R. Brooks, *ibid.*, **63**, 1173 (1975).
- (2) S. B. Jaffe and J. B. Anderson, *J. Chem. Phys.*, **51**, 1057 (1969).
- (3) J. C. Polanyi, *Acc. Chem. Res.*, **5**, 161 (1972).
- (4) (a) K. R. Kopecky, J. E. Filby, C. Mumford, P. A. Lockwood, and J. Y. Ding, *Can. J. Chem.*, **53**, 1103 (1975); (b) D. R. Kearns, *Chem. Rev.*, **71**, 395 (1971); (c) I. Simo and J. Stauff, *Chem. Phys. Lett.*, **34**, 326 (1975).
- (5) Y. N. Chiu, *J. Chem. Phys.*, **64**, 2997 (1976).
- (6) D. J. Bogan, R. S. Sheinson, and F. W. Williams, *J. Am. Chem. Soc.*, **98**, 1034 (1976).
- (7) D. J. Bogan, R. S. Sheinson, F. W. Williams, and R. G. Gann, *J. Am. Chem. Soc.*, **97**, 2560 (1975).
- (8) D. J. Bogan, R. S. Sheinson, and F. W. Williams, *J. Photochem.*, **5**, 156 (1976).
- (9) J. B. Anderson, R. P. Andres, and J. B. Fenn, *Adv. Chem. Phys.*, **10**, 275 (1966).
- (10) R. E. Huie and J. T. Herron, *Int. J. Chem. Kinet.*, **5**, 197 (1973).
- (11) (a) J. B. Anderson, *Entropie*, **18**, 33 (1967); (b) "Molecular Beams from Nozzle Sources", in press; (c) J. B. Anderson and P. Davidovits, *Science*, **187**, 64L (1974).
- (12) (a) R. J. Gallagher and J. B. Fenn, *J. Chem. Phys.*, **60**, 3487, 3492 (1974); (b) J. B. Fenn, private communication; (c) R. J. Gallagher, Ph.D. Thesis, Yale University, 1972.
- (13) G. O. Brink, *Rev. Sci. Instrum.*, **37**, 857, 1626 (1966).
- (14) N. R. Daly, *Rev. Sci. Instrum.*, **31**, 264 (1960).
- (15) D. J. Bogan, private communication.
- (16) S. M. McElvain and D. Kundiger, "Organic Syntheses", Collect. Vol. III, Wiley, New York, N.Y., 1955, p 506.
- (17) L. Brandsma and J. F. Arens, *Recl. Trav. Chim. Pays-Bas*, **81**, 33 (1962).
- (18) G. Laban and R. Mayer, *Z. Chem.*, **7**, 12 (1967).
- (19) M. S. Newman and M. C. V. Zwan, *J. Org. Chem.*, **38**, 2910 (1973).
- (20) R. D. Ashford and E. A. Ogryzlo, *J. Am. Chem. Soc.*, **97**, 3604 (1975).
- (21) (a) J. P. Paris, *Photochem. Photobiol.*, **4**, 1059 (1965); (b) A. N. Fletcher and C. A. Heller, *J. Phys. Chem.*, **71**, 1507 (1967).
- (22) H. E. O'Neal and W. H. Richardson, *J. Am. Chem. Soc.*, **92**, 6553 (1970).
- (23) L. B. Harding and W. A. Goddard, *J. Am. Chem. Soc.*, **99**, 4520 (1977).
- (24) M. J. S. Dewar and W. Thiel, *J. Am. Chem. Soc.*, **97**, 3978 (1975).